

# Technical data sheet for CONVOTHERM OES 6.10

## General features:

- Advanced Closed System (for detailed information, see reverse)
- Sturdy model in stainless steel
- Height-adjustable feet 120 - 160 mm
- Anti-wear door contact switch
- Oven has rounded corners
- Pivoting rack and removable suction plate
- Hygienic plug-in gasket for day-to-day cleaning, easy to remove
- Self-emptying condensate drip tray
- Oven light with shock-resistant glass cover
- Permanent self-diagnosis for error recognition
- System with full-text error description
- Emergency programme mode: appliance operates with limited functionality even when technical defects arise
- Detailed documentation, spare parts lists, circuit diagrams in appliance
- Injector version

## Standard features:

- Disappearing door
- Butterfly valve: less steam escapes when oven door is opened
- Hand shower with continuously variable setting
- Door rotary lever lock with raised position, supplementary function and safety function
- Fan with auto-reverse
- Seamlessly welded high-shine oven chamber
- Lengthwise shelf
- Double glass door with integrated lock position and self-emptying condensate drip tray
- Module-based processor control with plain text display and module auto-control
- Crisp&Tasty (demoisturising in closed system with several levels)
- Auxiliary timer
- Easy to operate with menus/icons
- Bright graphic display
- Digital dial makes it easy to set temperature, time and core temperature
- Pre-set start time in real-time mode
- Programme in 250 recipes of up to 20 steps each
- CONVOTHERM Cookbook with pre-programmed recipes
- Cook & Hold and Delta-T cooking
- RS 232 interface
- Can be connected up to energy optimisation unit
- Programme protection (prevents programmes in progress from being interrupted through energy optimisation unit)
- Save all settings and recipes in additional memory module (identity module)

## Optional features:

- CONVOClean system (automatic cleaning programme)
- Press&Go (symbol)
- Multi-point core temperature sensor
- PC-HACCP software for fully automated documentation and archiving of cooking processes
- PC-Control software manages up to 31 CONVOTHERM combi steamers
- RS 232, RS 485 and USB communication modules to network up to 31 CONVOTHERM combi steamers
- RS 232, RS 485 and USB communication modules plus Ethernet to network up to 31 CONVOTHERM combi steamers and for Internet connection
- Grill version with separate fat drain
- Version for ships, version for prisons
- Special voltage levels
- Baking area 600x400
- Reduced fan speed for cooking sensitive products (programmable)
- Reduced heat output for operating at peak periods (programmable)



## Cooking programmes

**Steaming at** 30°C-120°C



- For steaming, stewing and poaching.

**Superheated steam** 100°C-250°C



- For roasting and baking.

**Convection** 30°C-250°C



- For grilling, quick roasting, baking, toasting and gratinating.

**Regeneration** 120°-160°C



- For fast heating of prepared dishes ready to be arranged on the plate or platter.

## Accessories

- Oven stands in various models
- Stacking kit for 6.10 tabletop models on 6.10 or 10.10
- Extraction hood
- Condensation hood
- Plated banqueting system
- Thermal cover
- Chicken set
- Baking sheets
- CONVOClean new (oven cleaner, non-hazardous, kind to the environment)
- CONVOClean forte (oven cleaner)
- CONVOCare (nozzle cleaner)
- CONVOCal (decalcifier)
- CONVOCal forte (decalcifier)

# Technical data sheet for CONVOTHERM OES 6.10

## Body of appliance

Width (mm)	932
Depth (mm)	805
Height (mm)	852
Weight (kg)	170

## Appliance + packaging

Width (mm)	1127
Depth (mm)	950
Height (mm)	1032
Weight (kg)	200

## Shelves

1/1 GN	7
2/1 GN	-
Shelf spacing (mm)	68

Baking area 600x400	6
Shelf spacing 600x400	78

## Plated banqueting system

Number of plates	20
------------------	----

latent heat kJ/h*	6804
sensitive heat kJ/h*	4536
*calculated according to VDI 2052	

## Advanced Closed System

- with automatically regulated steam injection
- no manual input of moisture levels required
- no waiting time for cooling off
- switch immediately to any steam programme even at oven temperatures over 100°C
- low water and energy consumption
- Crisp&Tasty for perfect results
- no negative effect on air in the kitchen during the cooking process

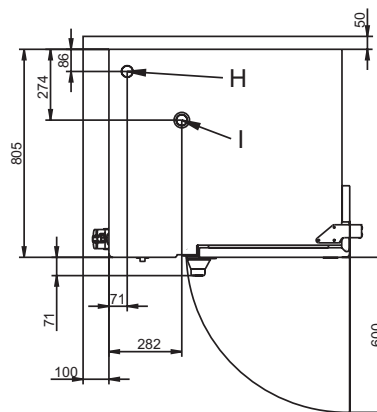
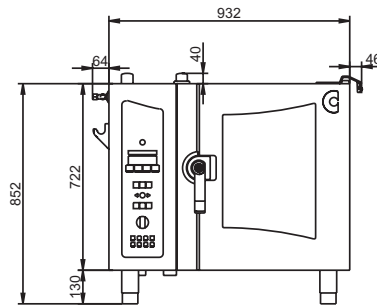

- A = Gfl" soft water supply connection
- B = Gfl" cold water supply connection
- C = DN50 waste water connection
- D = Power connection
- E = Potential compensation
- F = Clear rinse connection
- G = Cleaner connection
- H = Vent pipe
- I = Low-pressure failsafe device

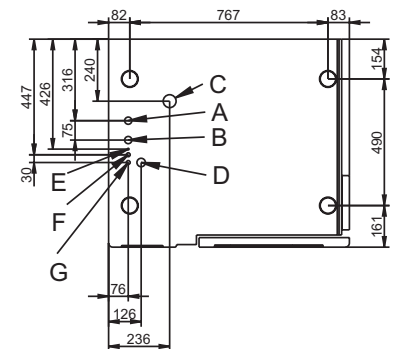

## Installation conditions

(for precise installation instructions, please refer to our installation manual)

Power connection  
AC connection  
Multi-pin circuit breaker, effective separator installed near appliance and supply line  
Voltage 3/N/PE 380-415V~ 50/60 Hz  
Connection for potential compensation

Special voltage level (optional)  
3/PE 220-240V~ 50/60Hz  
3/PE 400V~ 50/60Hz  
3/PE 440V~ 60Hz

Installation conditions (customer premises)

Power connection	
Connection value (kW)	11,4
Convection power output (kW)	10,5
Rated current [A]	15,3

For connection value, voltage and fuse rating, refer also to the circuit diagram.

IPX 5 spray-proof and hose-proof.

## Installation distance from wall

- rear	50 mm
- right	50 mm
- left	100 mm

If heat sources are located near the combi steamer, ensure that an adequate safe distance is maintained.

**Installation in accordance with EVU regulations** only install on horizontal surfaces intended for this purpose and not on flammable walls.

## Water connection (\*drinking water quality)

- cold water\*
- flow pressure (2 to 6 bar)
- soft water connection\*
- shut-off valve with return flow inhibitor and dirt filter
- water supply (G3/4") with 1/2" pressure pipe

Funnel siphon (workstation) < 70 dB