

Technical data sheet for CONVOTHERM OES 10.10

General features:

- Advanced Closed System (for detailed information, see reverse)
- Sturdy model in stainless steel
- Height-adjustable feet 120 - 160 mm
- Anti-wear door contact switch
- Oven has rounded corners
- Pivoting rack and removable suction plate
- Hygienic plug-in gasket for day-to-day cleaning, easy to remove
- Self-emptying condensate drip tray
- Oven light with shock-resistant glass cover
- Permanent self-diagnosis for error recognition
- System with full-text error description
- Emergency programme mode: appliance operates with limited functionality even when technical defects arise
- Detailed documentation, spare parts lists, circuit diagrams in appliance
- Injector version



Cooking programmes

Steaming at 30°C-120°C



- For steaming, stewing and poaching.

Superheated steam 100°C-250°C



- For roasting and baking.

Convection 30°C-250°C



- For grilling, quick roasting, baking, toasting and gratinating.

Regeneration 120°-160°C



- For fast heating of prepared dishes ready to be arranged on the plate or platter.

Accessories

- Oven stands in various models
- Stacking kit for 6.10 tabletop models on 6.10 or 10.10
- Extraction hood
- Condensation hood
- Plated banqueting system
- Thermal cover
- Chicken set
- Baking sheets
- CONVOClean new (oven cleaner, non-hazardous, kind to the environment)
- CONVOClean forte (oven cleaner)
- CONVOCare (nozzle cleaner)
- CONVOCal (decalcifier)
- CONVOCal forte (decalcifier)

Standard features:

- Disappearing door
- Butterfly valve: less steam escapes when oven door is opened
- Hand shower with continuously variable setting
- Door rotary lever lock with raised position, supplementary function and safety function
- Fan with auto-reverse
- Seamlessly welded high-shine oven chamber
- Lengthwise shelf (2/1 GN)
- Double glass door with integrated lock position and self-emptying condensate drip tray
- Module-based processor control with plain text display and module auto-control
- Crisp&Tasty (demoisturising in closed system with several levels)
- Auxiliary timer
- Easy to operate with menus/icons
- Bright graphic display
- Digital dial makes it easy to set temperature, time and core temperature
- Pre-set start time in real-time mode
- Programme in 250 recipes of up to 20 steps each
- CONVOTHERM Cookbook with pre-programmed recipes
- Cook & Hold and Delta-T cooking
- RS 232 interface
- Can be connected up to energy optimisation unit
- Programme protection (prevents programmes in progress from being interrupted through energy optimisation unit)
- Save all settings and recipes in additional memory module (identity module)

Optional features:

- CONVOClean system (automatic cleaning programme)
- Press&Go (symbol)
- Multi-point core temperature sensor
- PC-HACCP software for fully automated documentation and archiving of cooking processes
- PC-Control software manages up to 31 CONVOTHERM combi steamers
- RS 232, RS 485 and USB communication modules to network up to 31 CONVOTHERM combi steamers
- RS 232, RS 485 and USB communication modules plus Ethernet to network up to 31 CONVOTHERM combi steamers and for Internet connection
- Grill version with separate fat drain
- Version for ships, version for prisons
- Special voltage levels
- Baking area 600x400
- Reduced fan speed for cooking sensitive products (programmable)
- Reduced heat output for operating at peak periods (programmable)

Technical data sheet for CONVOTHERM OES 10.10

Body of appliance

Width (mm)	932
Depth (mm)	805
Height (mm)	1120
Weight (kg)	215

Appliance + packaging

Width (mm)	1127
Depth (mm)	950
Height (mm)	1300
Weight (kg)	250

Shelves

1/1 GN	11
2/1 GN	-
Shelf spacing (mm)	68

Baking area 600x400	9
Shelf spacing 600x400	80

Plated banqueting system

Number of plates	32
------------------	----

latent heat kJ/h*	12247
sensitive heat kJ/h*	8165

*calculated according to VDI 2052

Advanced Closed System

- with automatically regulated steam injection
- no manual input of moisture levels required
- no waiting time for cooling off
- switch immediately to any steam programme even at oven temperatures over 100°C
- low water and energy consumption
- Crisp&Tasty for perfect results
- no negative effect on air in the kitchen during the cooking process

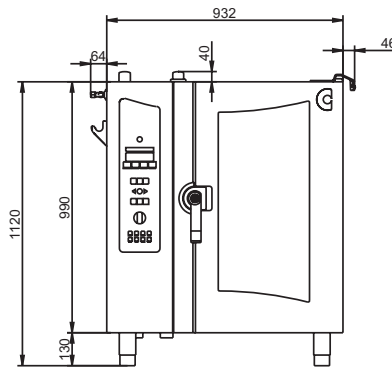

- A = GfI" soft water supply connection
- B = GfI" cold water supply connection
- C = DN50 waste water connection
- D = Power connection
- E = Potential compensation
- F = Clear rinse connection
- G = Cleaner connection
- H = Vent pipe
- I = Low-pressure failsafe device

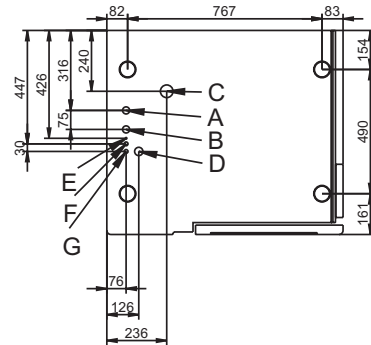
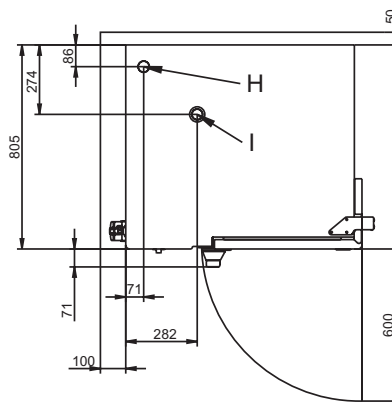

Installation conditions

(for precise installation instructions, please refer to our installation manual)

Power connection

AC connection

Multi-pin circuit breaker, effective separator installed near appliance and supply line
Voltage 3/N/PE 380-415V~ 50/60 Hz

Connection for potential compensation, optional special voltage level

Special voltage (optional)

3/PE 220-240V~ 50/60Hz

3/PE 400V~ 50/60Hz

3/PE 440V~ 60Hz

Installation conditions (customer premises)

Power connection

Connection value (kW) 19,8

Convection power output (kW) 18,9

Rated current [A] 26,3

IPX5 spray-proof and hose-proof.

For connection value, voltage and fuse rating, refer also to the circuit diagram.

Installation distance from wall

- rear	50 mm
- right	50 mm
- left	100 mm

If heat sources are located near the combi steamer, ensure that an adequate safe distance is maintained.

Installation in accordance with EVU regulations only install on horizontal surfaces intended for this purpose and not on flammable walls.

Water connection (*drinking water quality)

- cold water*
- flow pressure (2 to 6 bar)
- soft water connection*
- shut-off valve with return flow inhibitor and dirt filter
- water supply (G3/4") with 1/2" pressure pipe
- DN 50 mm water outflow with noise emission

Funnel siphon (workstation) < 70 dB